

Teach someone to read 7

This chapter introduces the new sounds "u", "aai" and "f", and revises a lot of old ones, in preparation for reading the book *"Ben en Boet 2"*.

Remember to make a story of each sound chart, where possible. In the "o, i, u" one, you can talk about the naughty kiddie standing on the cupboard, hiding in the cupboard, and then climbing out in hurry when mother comes. In the second, you could say, "Laat ons die foto en die blompot op die tafel sit..."



This chapter fits in with the rest of the course like this:

Chapter 1 : First sounds **k m s t a o n** and words with them.

Chapter 2 : New sounds **e p i a a y b l**

Chapter 3 : **h d ie**

Chapter 4 : **r ee** and the stories in the booklet *"Die Huis in Klipplaat"*

Chapter 5 : **oo v w** and the stories in *"Ben en Boet"*

Chapter 6 : **oe g** and the stories in *"Dit reën"*

Chapter 7 : **u f aai** and the stories in *"Ben en Boet 2"*

Chapter 8 : **eu** and the stories in *"Winkel toe"*

Chapter 9 : **j ui**

Chapter 10 : **ou ei** and the stories in *"Bettie en Jannie"*

Chapter 11 : **ng uu** and the stories in *"Die Jakkals"*, *"Die storm"* and *"Rosie"*

Chapter 12 : **tjie jie oei eeu** and then *"Boetie"*, *"Ben en Boet 3"*

"Ben en Boet 4" and *"Ben en Boet 5"*

u

bus

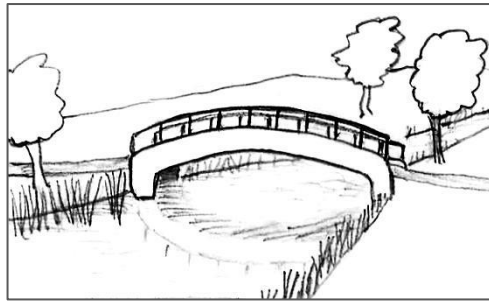

bul



brug

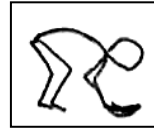

buk

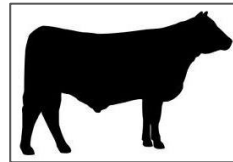

Ek buk.



My rug is seer.



Ek moet rus.

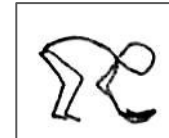

bok _____

bak _____

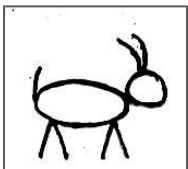

bek _____

buk _____



pik _____

o

i

u

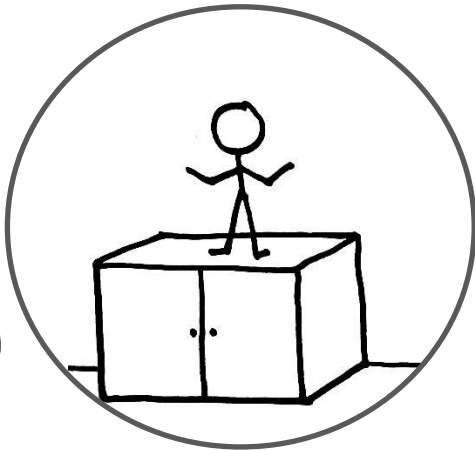

o

u

i

u

op

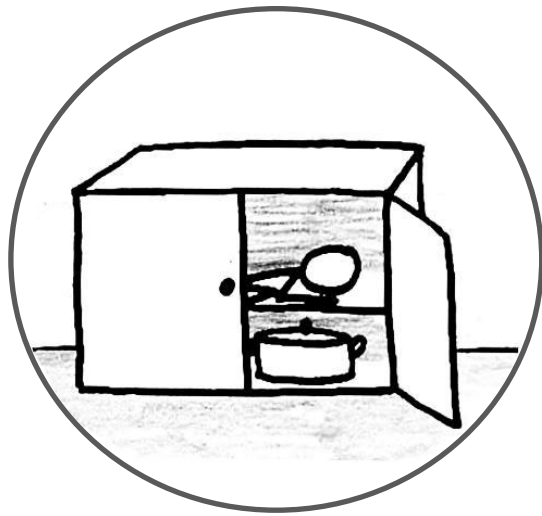

i

u

o

i

in

u

u

o

i

u

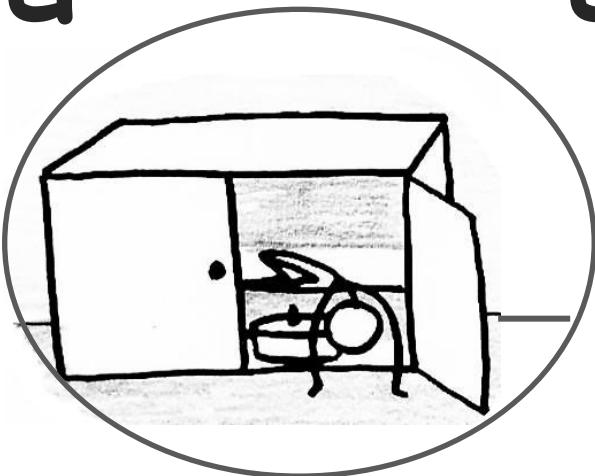

o

u

i

uit

Hulle hulle

Hy hardloop.

Sy hardloop.

Hulle hardloop.

Hulle stap.

Hy stap.

Sy stap.

Sy dans.

Hulle dans.

Hy dans.

'n stuk karton

'n stukkie koek

'n stukkie brood

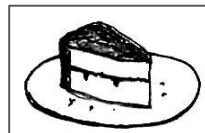
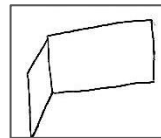
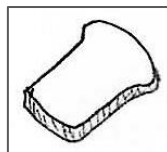
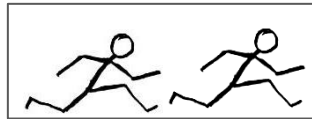
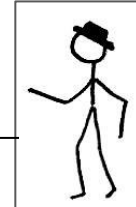
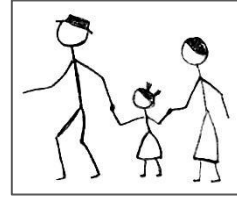
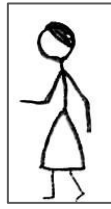

u

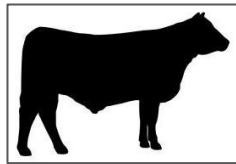

buk

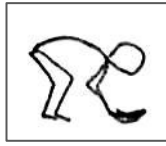

bul

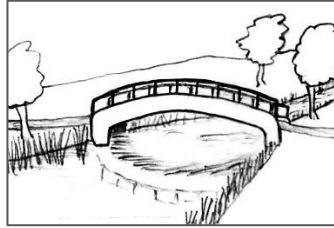

bus



rus

rug

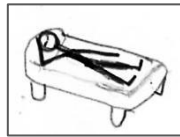

brug

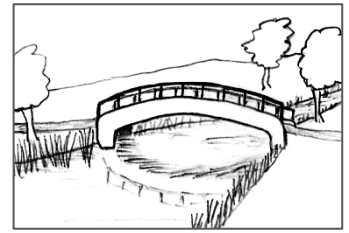

wurm

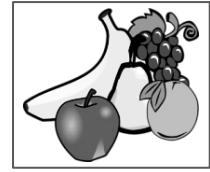

warm

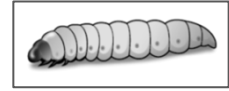

brug

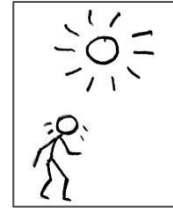

vrugte

buk



bok

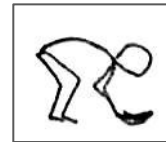

Die wurm

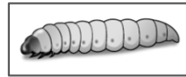

Ek eet 'n appel. Die appel is lekker.

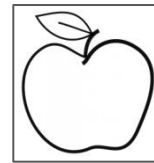

Skielik sien ek 'n wurm!



Ek skrik! Daar is 'n wurm in my appel!

Ek  'n  _____.

Skielik  _____ ek 'n  _____!

Ek  _____!

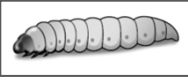
Daar is 'n  _____ in my  _____!

Psalm 121 : 1 - 2

1. Ek slaan my oë op na die berge,
waar sal my hulp vandaan kom?

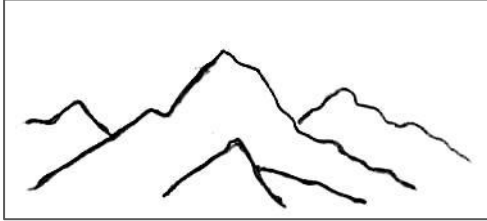

2. My hulp is van die Here
wat hemel en aarde gemaak het.

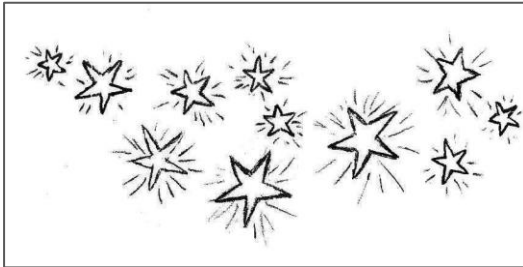

f

t

b



b

t

f

b

foto

f

t

b

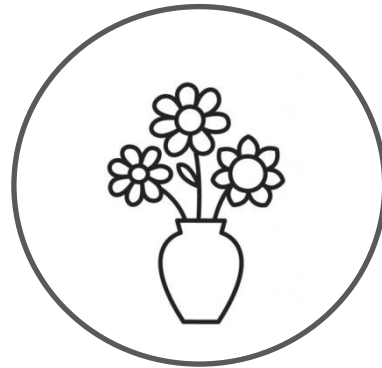

f

blompot

t

f

b

f

t



t

b

f

tafel

f

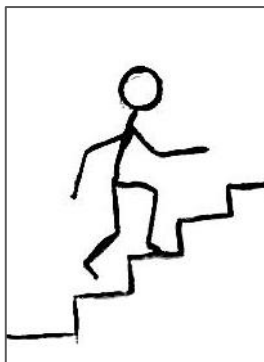

op

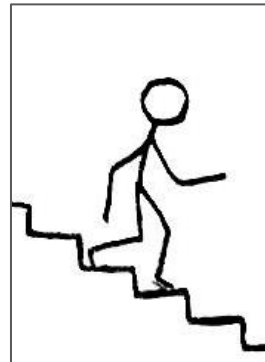

af

foto



fiets

5

skryf



vyf

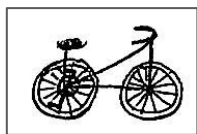

vyftien



tafel

15

graaf

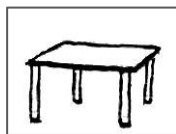

buffel

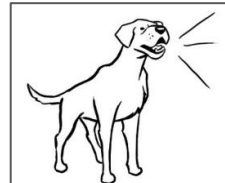

koffie



kalf

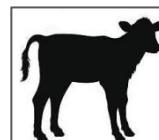

blaf

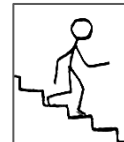

verf

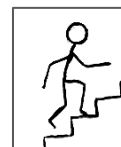

op



af



1 _____ 2 _____ 3 _____ 4 _____ 5 _____

6 _____ 7 _____ 8 _____ 9 _____ 10 _____

drie een ses vier vyf agt tien twee sewe nege

v

w

f



veld

w

f

v

f

w

v



windpomp

f

v

f

w

v

w



foto

f

v

w

v

f

v

w

f

bul

kalf

perd

vark

hond

kat

bok

skaap

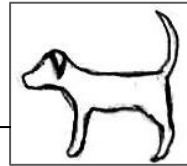
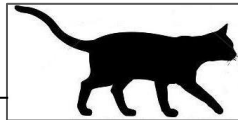
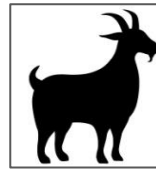
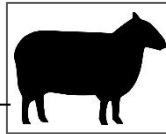
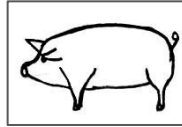
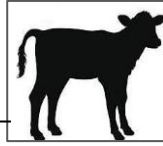
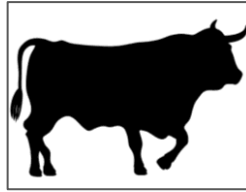
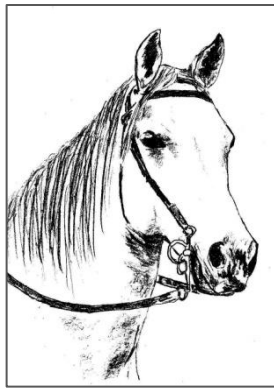

buffel

koedoe

by

vlieg

musket

wurm

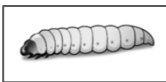

Die brug

Ek sit in 'n bus.

Die bus ry en ry.

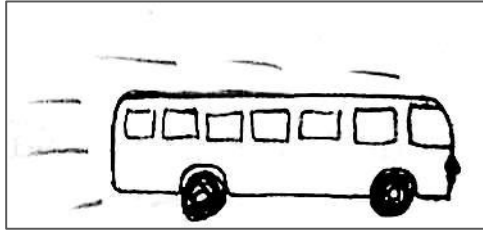

Toe kom ons by 'n mooi brug.

Ek neem 'n foto van die brug.

Die brug lê oor 'n mooi rivier.

Die bus ry oor die brug.

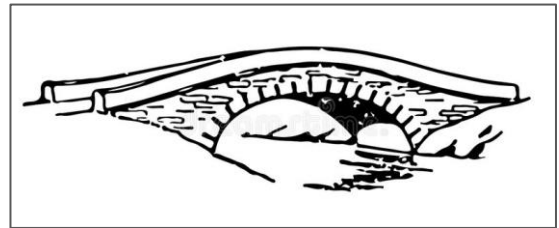

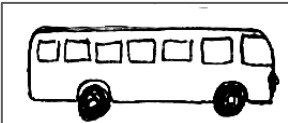

Ek is bly dat ek daardie mooi brug gesien het.

Ek  _____ in 'n  _____.

Die  _____ kom by 'n mooi  _____.

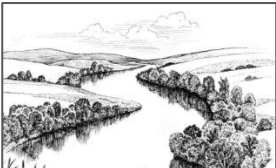
Ek neem 'n  _____ van die  _____.

Die  _____ lê oor 'n mooi  _____.

Die  _____ ry oor die  _____.

Ek is  _____ dat ek daardie mooi  _____
gesien het.

bus

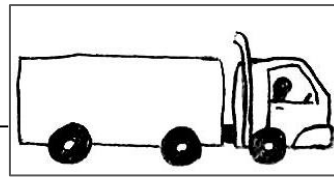

trekker

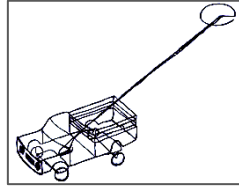

bakkie



motor

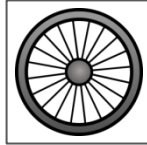

draadkar



lorrie

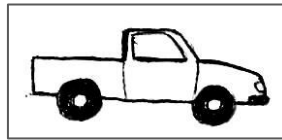

wiel

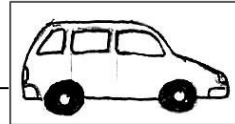

Die bakkie staan.



Die bakkie ry.



Die man laai iets op die bakkie.



Die bus staan.

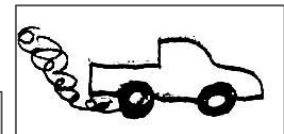

Die bus ry.

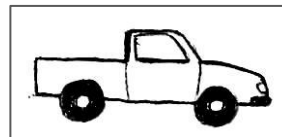

Die draadkarre ry.

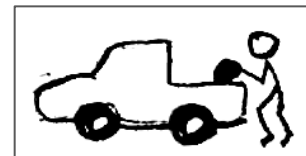

aai

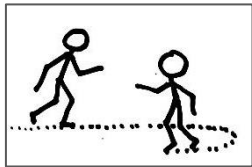

laai

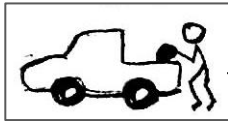

saai



draai

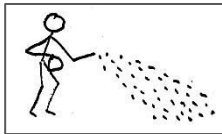

braai

ooi

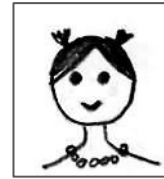

gooi

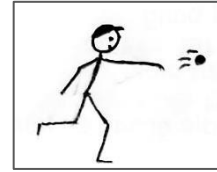

rooi

mooi

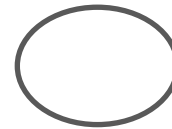

Ek koop 'n stukkie wors.

Ek **braai** die wors.

Dit is baie lekker!

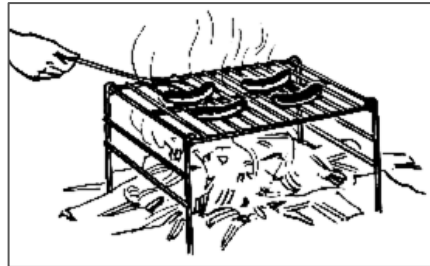

Ek loop in die veld.

Ek sien 'n windpomp.

Die wind **waai** en die windpomp **draai**.

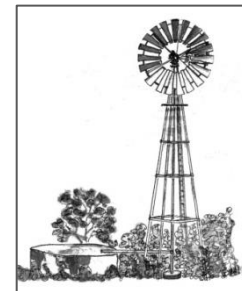

Ek  _____ in die  _____ .

Ek  _____ 'n  _____ .

Die  _____ waai en die  _____ draai.

aa

aa

oo

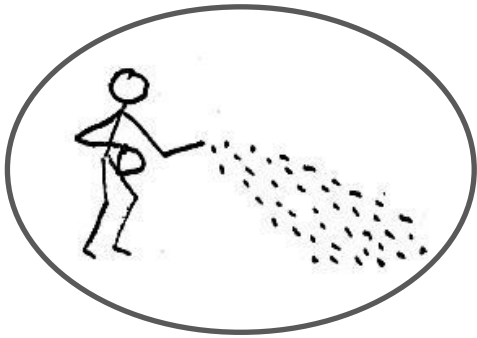

aa

aa

saai

oo

aa

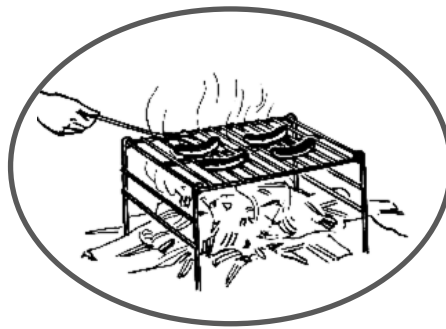

aa

braai

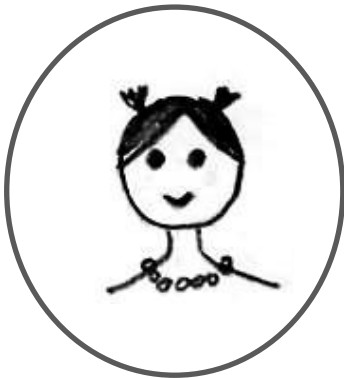

oo

aa

aa

moo

aa

oo

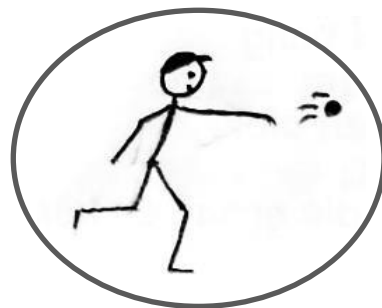

goo

oo

aa

aa

Galasiërs 6 : 7

Net wat die mens saai, dit sal hy ook maai.

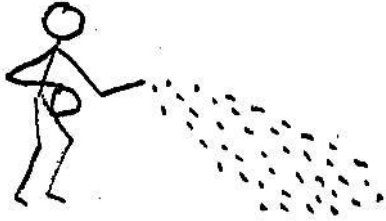

Romeine 5 : 8

God bewys sy liefde tot ons daarin
dat Christus vir ons gesterf het
toe ons nog sondaars was.



1 Johannes 4 : 19

Ons het Hom lief
omdat Hy ons eerste
liefgehad het.

Hy hardloop.



Sy hardloop.

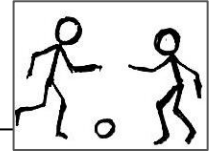

Hulle hardloop.

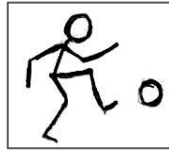

Hulle klim.



Hy klim.

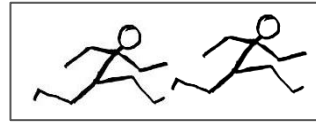

Sy klim.



Sy gaan kerk toe.

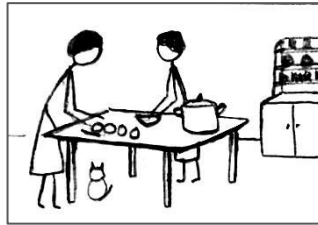

Hulle gaan kerk toe.

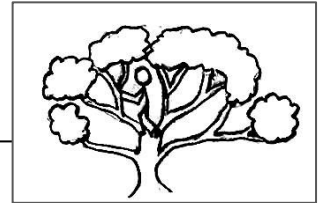

Hy gaan kerk toe.

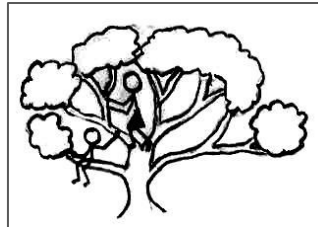

Hy speel.

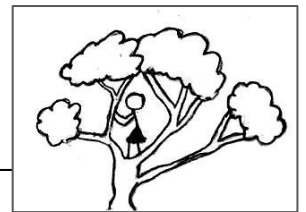

Sy speel.

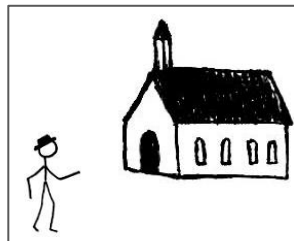

Hulle speel.

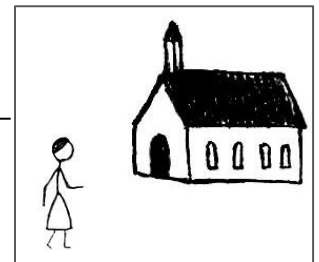

Hulle maak kos.

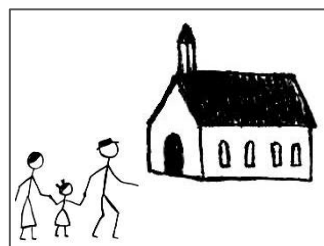

Sy maak kos.

buk

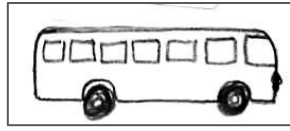

koffie



bul



skryf



bus



verf



rug

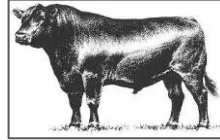

blaf



brug

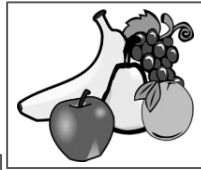

graaf



vrugte

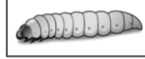

kalf



wurm

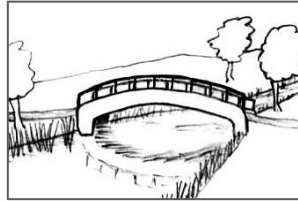

tafel

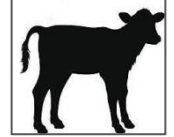

foto

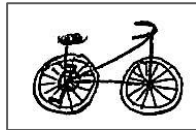

laai



vyf



braai

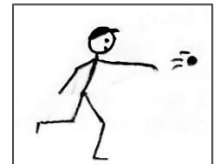

buffel

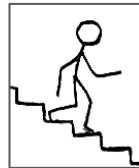

draai

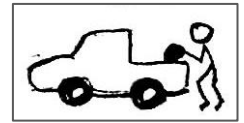

kalfie



saai

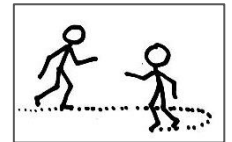

af



gooi

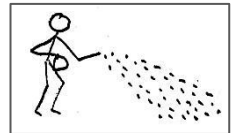

fiets

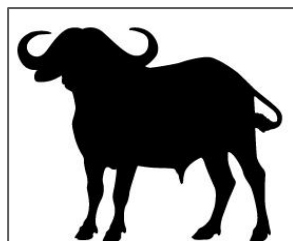

mooi

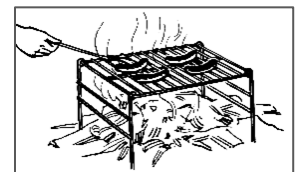

vinnig

stadig

Die water loop vinnig.

Die water loop stadig.

Die man loop vinnig.

Die man loop stadig.

Die bakkie ry stadig.

Die bakkie ry vinnig.

Die draadkar ry vinnig.

Die draadkar ry stadig.

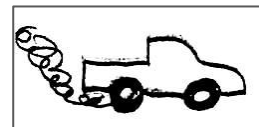
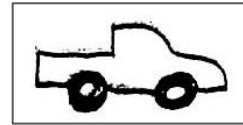
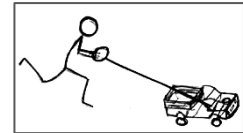
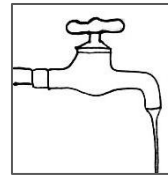
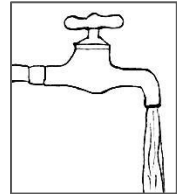

Trek 'n lyn na die regte prent, en skryf vinnig of stadig :

Die oom loop _____ .



Die man hol _____ .

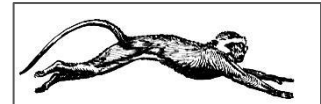

Die aap hardloop _____ .



Die skilpad loop _____ .

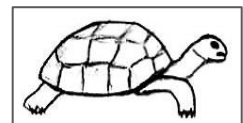

Die trekker ry _____ .

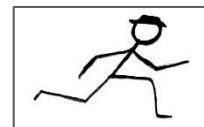

The booklet "*Ben en Boet 2*" fits in here. The text is reproduced here, but it is better to print up the little A5 booklet.

Once again, the story is set in Klipplaat. Contact me, free of charge, if you would like to use these stories but would like to make them about the place where your students live.

Ben en Boet

2



Ligte vir die draadkarre

Ben wil sy draadkar mooi maak.

Hy het 'n stuk karton en vier doppies.

"Kom, Boet," sê hy.

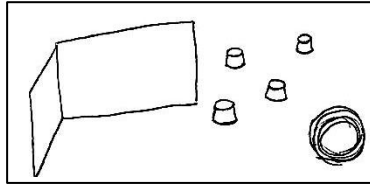

"Kom ons maak ons draadkarre mooi."

Hulle werk eers aan Ben se draadkar.

Hulle sny die karton.

Op die karton maak hulle twee doppies vas.

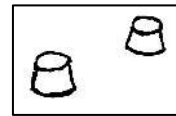

Hulle maak die doppies met draad vas.

Hulle maak die karton voor op Ben se kar vas.

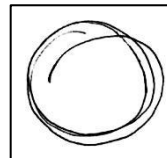
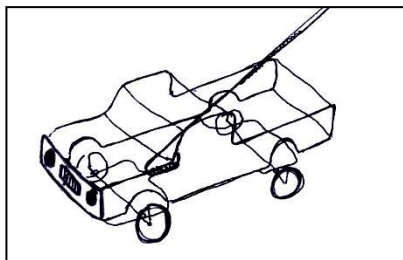

Die doppies lyk soos ligte.

"My draadkar het ligte!" sê Ben.

"Dit lyk mooi."

Hy lag. Hy is bly.

Boet lag ook.

"Ek wil ook ligte maak," sê hy.

"My kar wil ook ligte hê."

Hulle werk saam aan Boet se draadkar.

Hulle sny die karton.

Op die karton maak hulle twee doppies vas.



Hulle maak die karton voor op Boet se kar vas.

Hulle maak die karton met draad vas.

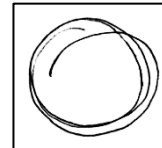

Die doppies lyk net soos ligte.

"My kar het ook ligte!" sê Boet.

Hy lag. Hy is bly.

Hy staan op.

"Kom, Ben," sê hy.

"Kom, laat ons ry."

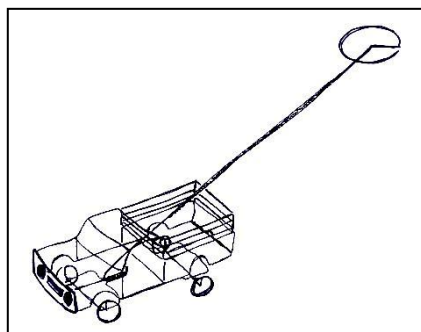

Vinnig!

Ben en Boet hol.

Die draadkarre ry.

Die karre ry vinnig.

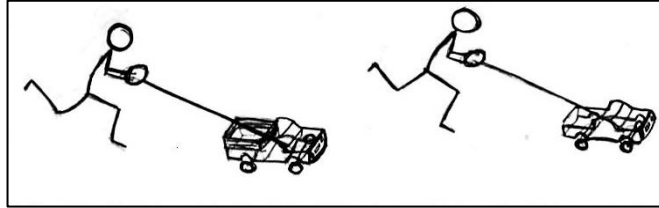

"Wag!" roep Boet.

"Ben, wag vir my! My wiel is los."

Ben wag. Boet kom. Ben sien die wiel.

Een van Boet se kar se wiele is los.

"Ek moet die wiel weer vasmaak," sê Boet.

Ben help vir Boet.

Hulle maak die wiel weer vas.

Boet se draadkar is reg.

Ben en Boet hol. Die draadkarre ry.

"Vinnig!" roep Ben. Hulle hol vinnig.

Die draadkarre ry ook vinnig.

Ben en Boet lag en lag.

Laai op!

Ben sê,

"Ek wil my draadkar sterk maak.

Ek wil die bak mooi sterk maak."

"Ek ook myne," sê Boet.

Hulle werk eers aan Ben se draadkar.

Ben sny 'n stuk karton.

Hulle maak die karton met draad vas.

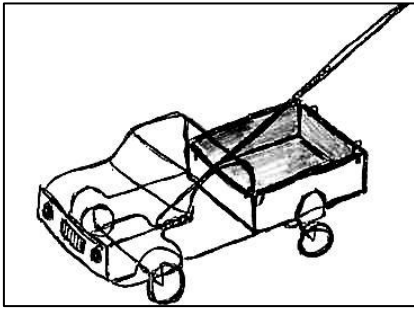

Die karton lê in die draadkar se bak.

Toe werk hulle ook aan Boet se kar.

"My kar is mooi sterk," sê Ben.

"Myne ook," sê Boet.

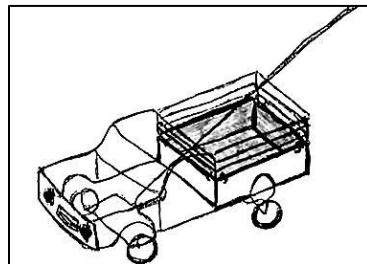

Hulle is bly.

"Kom ons ry," sê Ben.

Toe sien Boet 'n blik wat in die straat lê.

Dis 'n mooi skoon blik.

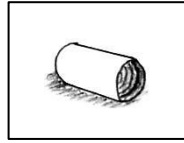

Hy tel die blik op en laai dit op sy draadkar.

Hy sit 'n paar klippe in die blik.

Ben laai ook 'n blik op.

Hulle laai hul karre vol blikke en klippe.

"Kom ons ry," sê Boet.

Hulle hol.

Die draadkarre ry.

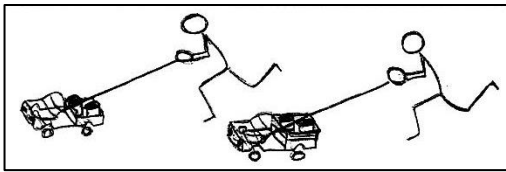

"Vinnig!" roep Ben.

Hulle hol vinnig.

Die blikke en klippe raas.

Ben en Boet lag en lag.

Stadig!

Ben en Boet ry met hulle draadkarre.

Hulle ry in die strate van Klipplaat.

Op en af ry die draadkarre in die strate van Klipplaat.

Die blikke en klippe raas.



Ben en Boet hol.

Die draadkarre ry vinnig.

Die draadkarre ry vinniger en vinniger.

Die blikke en klippe raas.

Ben en Boet lag en lag.

Ben ry voor.

Die straat maak 'n draai.

"Stadig!" roep Boet. "Stadig!" Maar dis te laat.

Ben se draadkar ry om die draai,
maar hy ry te vinnig. Sy draadkar slaan om.

Die blikke val, die klippe rol.

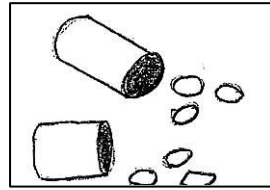

Boet help vir Ben om alles op te tel.

Hulle laai weer die blikke op Ben se draadkar.

Hulle sit weer die klippe in die blikke.

Ben staan op.

"Vinnig!" roep hy.

Hulle ry weer vinnig.

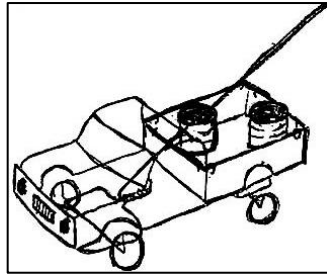









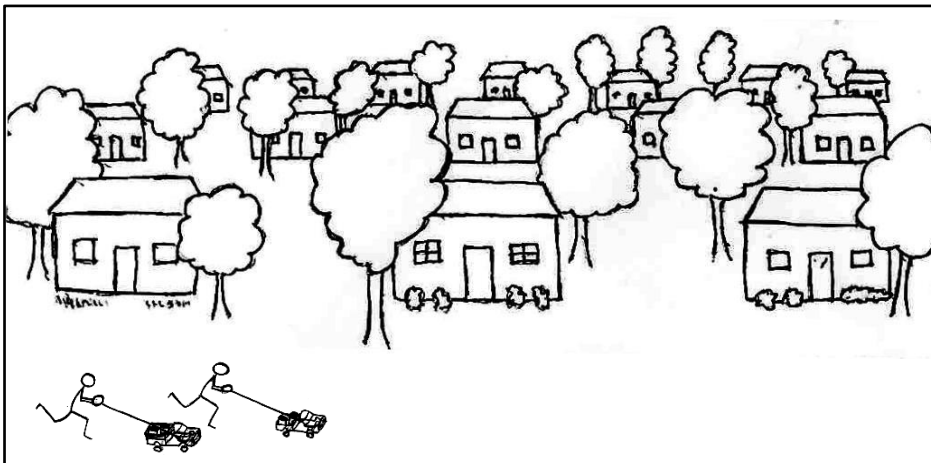

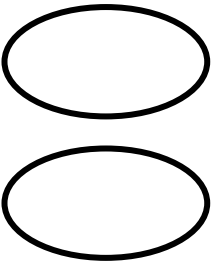

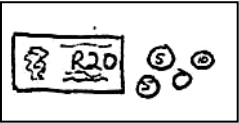
Die blikke en klippe raas.

Op en af ry die draadkarre in die strate van Klipplaat.

Ben en Boet lag en lag.

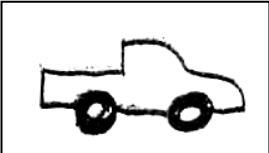
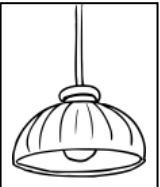
Hulle speel lekker saam.

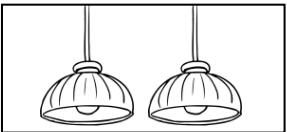

	geld		doppie
	gras		koppie
	groen		doppies
	geel		koppies
	lig		bokkie
	ligte		bakkie
	lag		bokkies
	nag		bakkies

'n stuk karton

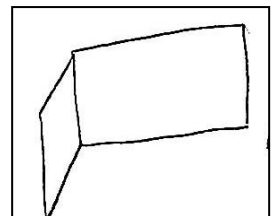
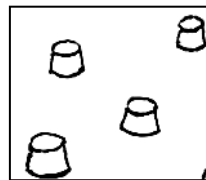

'n rol draad

vier doppies

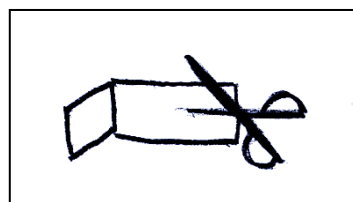

sny die karton

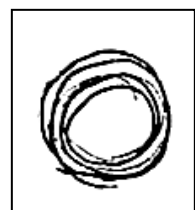

ie

10

drie

3

vier

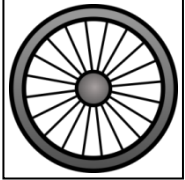

tien

4

sien



wiel



kar



karton

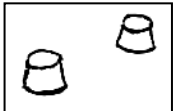

draad

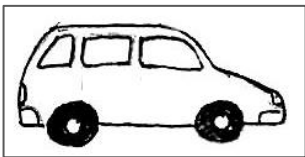

doppie

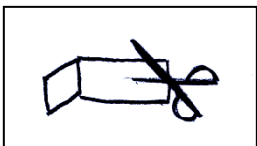

doppies



bokkie



bokkies

y

g



sny

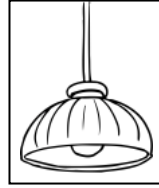

ry



kyk

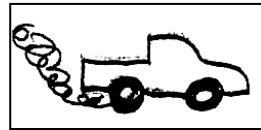

lag



lig

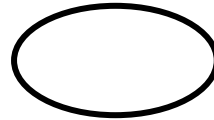

gras

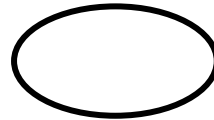

geel

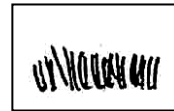

groen

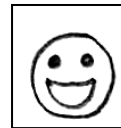

geld

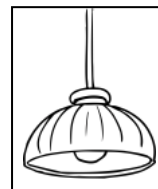

lag

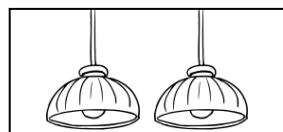

lig

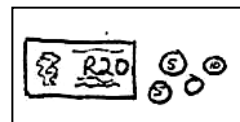

ligte

Ligte vir die draadkarre

Ben wil sy

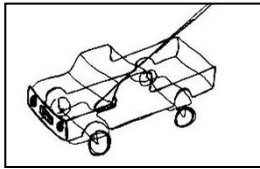

_____ mooi maak.

Hy het 'n stuk

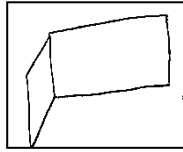

_____ en

4

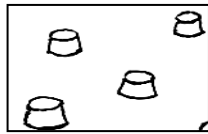

Hulle werk eers aan Ben se

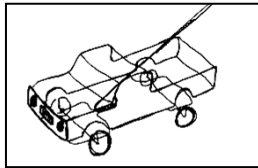

Hulle



_____ die

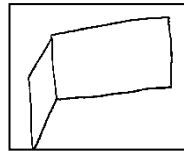

Op die

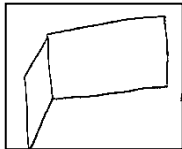

_____ maak hulle 2

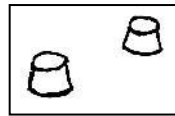

_____ vas.

Hulle maak die

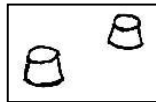

_____ met

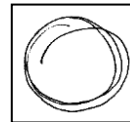

_____ vas.

Hulle maak die

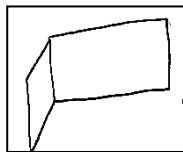

_____ voor op Ben se kar vas.

Die



_____ lyk soos

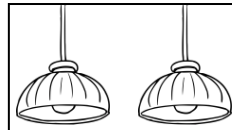

"My

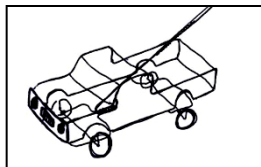

_____ het

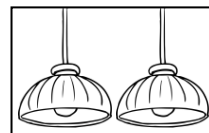

_____!" sê Ben.







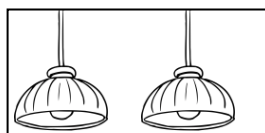



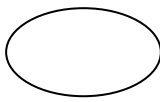

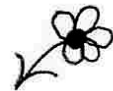







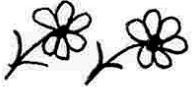

Hy is



Boet sê: "My kar wil ook



_____ hê."

blik		draai	
blikke		laai	
klip		saai	
klippe		rooi	
blom		blom	
blomme		blaar	
draadkar		blik	
Die man staan		draai	
Die man hol		draad	
Die man val		broek	
Die blikke val		brood	
Die sker sny		blom	
Die bakkie ry		blaar	